

Hose reel MGLE F

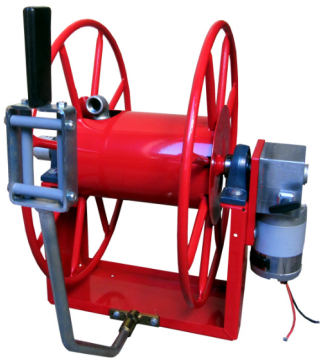

- Electric motor 12V or 24V with manual engageable clutch
- Control box with emergency stop switch
- Wireless remote control: on-off, forward-backward, stepless speed regulation
- Interchangeable battery and charger
- Casing in painted steel
- Axle with ball bearings
- Fixed mounting bracket
- Without hose

Item-No.	Designation	Medium	Max. length of the hose	Max. Ø	Max. pressure	Max. temp.	Motor
2.750.100	MGLE 124F	Water Pesticides High pressure Diesel Oil	80m	19mm	250bar	90°C	24V, 30u/min 400W - 20A
2.750.110	MGLE 224F		50m	25mm	250bar	90°C	
2.750.180	MGLE 924F		20m	38mm	200bar	60°C	
2.750.190	MGLE 1024F		130m	13mm	250bar	90°C	

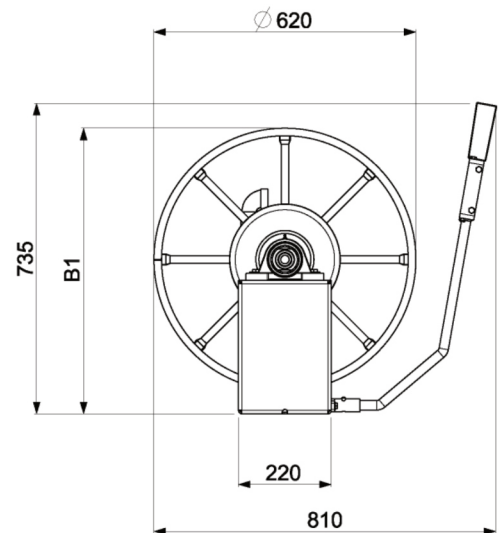
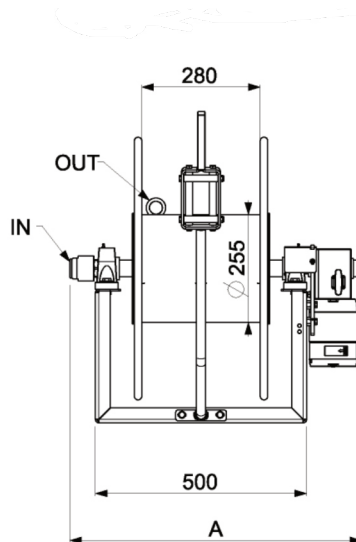
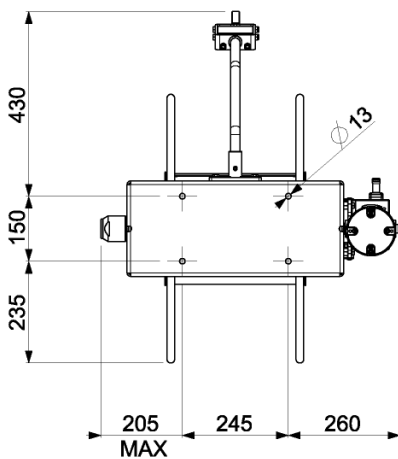

Item-No.	A	B	kg
2.750.100	745	675	39
2.750.110	750	675	40
2.750.180	750	675	40
2.750.190	770	690	45

Hose reel MGLE F

EBINGER

Technisches Equipment

Item-No.	Designation	Medium	Max. length of the hose	Max. Ø	Max. pressure	Max. temp.	Motor
2.750.120	MGLE 324F	Water Pesticides High pressure Diesel Oil	270m	13mm	250bar	90°C	24V, 30u/min 400W - 20A
2.750.130	MGLE 424F		180m	19mm	250bar	90°C	
2.750.140	MGLE 524F		100m	25mm	250bar	90°C	
2.750.150	MGLE 624F		40m	38mm	200bar	60°C	

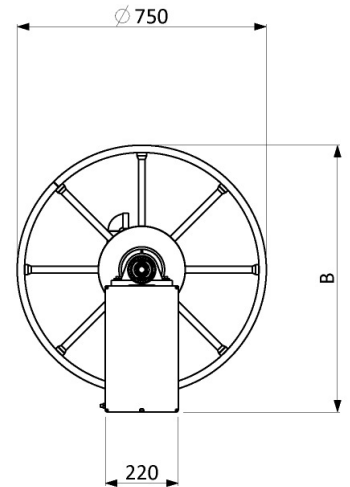
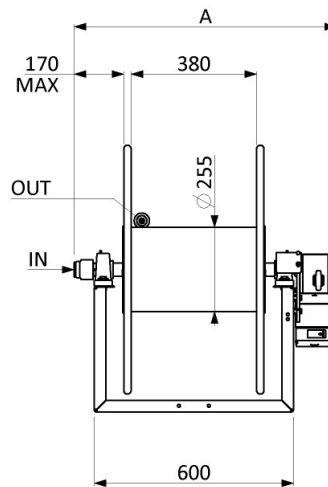
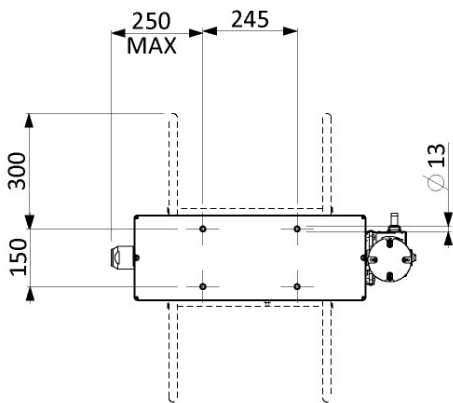

Item-No.	A	B	kg
2.750.120	845	805	46
2.750.130	850	805	47
2.750.140	850	805	47
2.750.150	870	820	51

Hose reel MGLE F

EBINGER

Technisches Equipment

Item-No.	Designation	Medium	Max. length of the hose	Max. Ø	Max. pressure	Max. temp.	Motor
2.750.195	MGLE 1124F	Water Pesticides High pressure Diesel Oil	18m	50mm	20bar	60°C	24V, 30u/min 400W - 20A

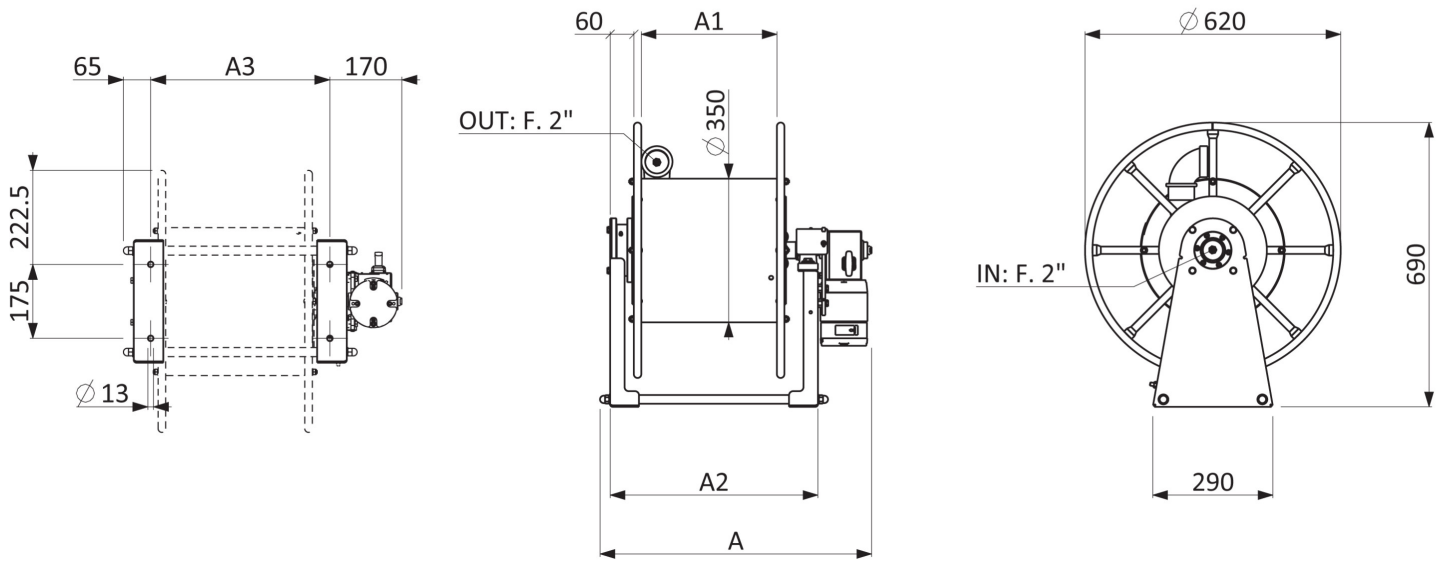

Item-No.	A	A1	A2	A3	kg
2.750.195	815	425	600	520	47

Hose reel MGLE F

Item-No.	Designation	Medium	Max. length of the hose	Max. Ø	Max. pressure	Max. temp.	Motor
2.750.160	MGLE 712F	Water Pesticides	30m	50mm	20bar	60°C	24V, 30u/min 400W - 20A
2.750.170	MGLE 812F	High pressure Diesel Oil	25m	50mm	20bar	60°C	

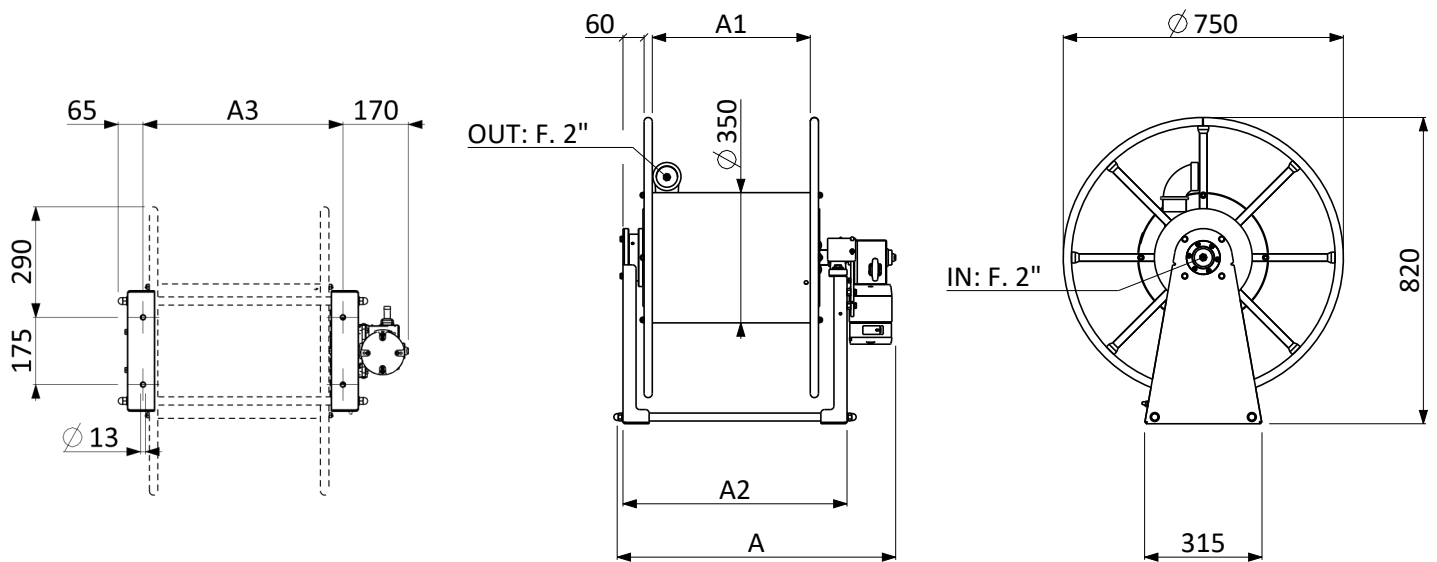

Item-No.	A	A1	A2	A3	kg
2.750.160	815	425	600	520	49
2.750.170	715	325	500	420	47

Hose reel MGLE F

EBINGER

Technisches Equipment

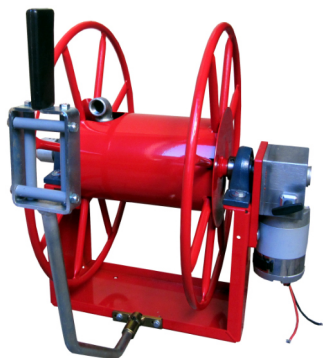

- Electric motor 230/400V with automatic freewheel
- Control box with emergency stop switch
- Wireless remote control: on-off, forward-backward, stepless speed regulation
- Casing in painted steel
- Axle with ball bearings
- Fixed mounting bracket
- Without hose

Item-No.	Designation	Medium	Max. length of the hose	Max. Ø	Max. pressure	Max. temp.	Motor
2.780.100	MGLE 140F	Water Pesticides High pressure Diesel Oil	100m	19mm	250bar	90°C	230V/400V, 27U/min 2,85A/1,6A-550W
2.780.110	MGLE 240F		50m	25mm	250bar	90°C	
2.780.180	MGLE 940F		20m	38mm	200bar	60°C	
2.780.190	MGLE 1040F		130m	13mm	250bar	90°C	

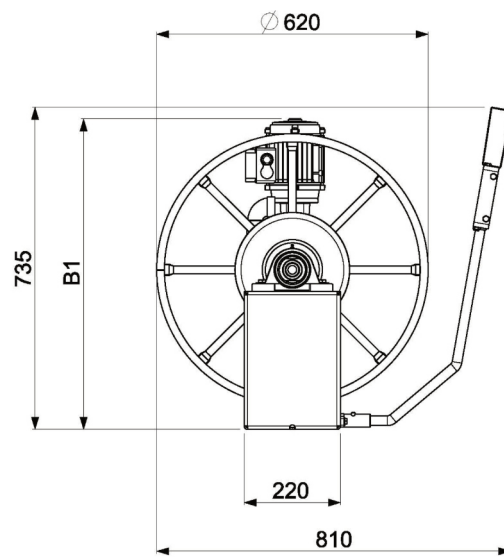
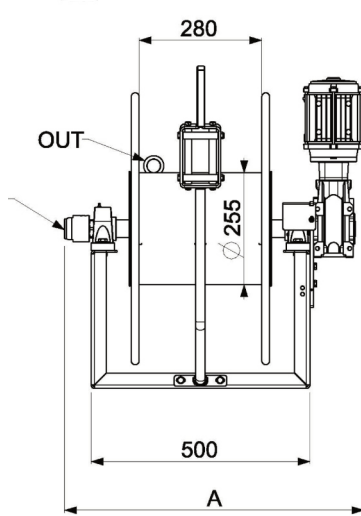
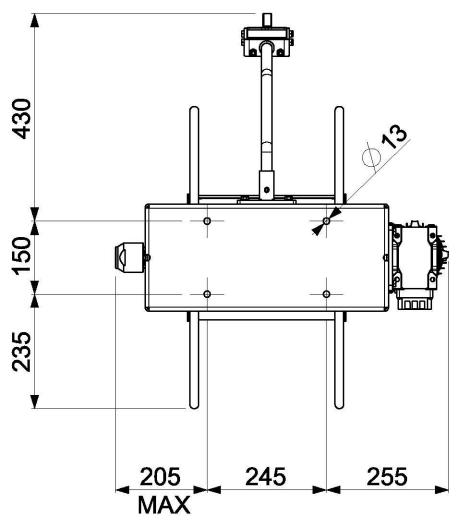

Item-No.	A	B	kg
2.780.100	765	675	58
2.780.110	765	675	59
2.780.180	785	690	63
2.780.190	760	675	58

Hose reel MGLE F

EBINGER

Technisches Equipment

Item-No.	Designation	Medium	Max. length of the hose	Max. Ø	Max. pressure	Max. temp.	Motor
2.780.120	MGLE 140F	Water Pesticides High pressure Diesel Oil	270m	13mm	250bar	90°C	230V/400V, 27U/min 2,85A/1,6A-550W
2.780.130	MGLE 240F		180m	19mm	250bar	90°C	
2.780.140	MGLE 940F		100m	25mm	250bar	90°C	
2.780.150	MGLE 1040F		40m	38mm	250bar	90°C	

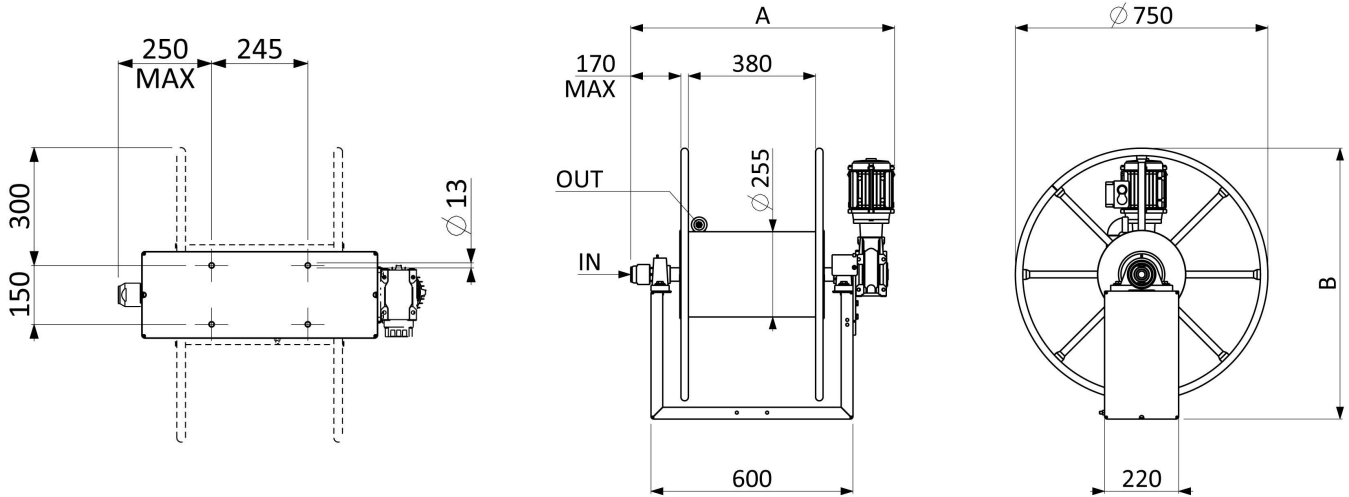

Item-No.	A	B	kg
2.780.120	860	805	65
2.780.130	865	805	65
2.780.140	865	805	66
2.780.150	885	820	70

Item-No.	Designation	Medium	Max. length of the hose	Max. Ø	Max. pressure	Max. temp.	Motor
2.780.160	MGLE 740F	Water Pesticides High pressure Diesel Oil	30m	50mm	60bar	20°C	230V/400V, 27U/min 2,85A/1,6A-550W
2.780.170	MGLE 840F		25m	50mm	60bar	20°C	
2.780.195	MGLE 1140F		18m	50mm	60bar	20°C	

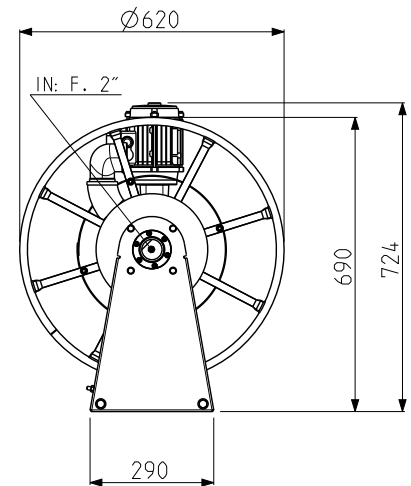
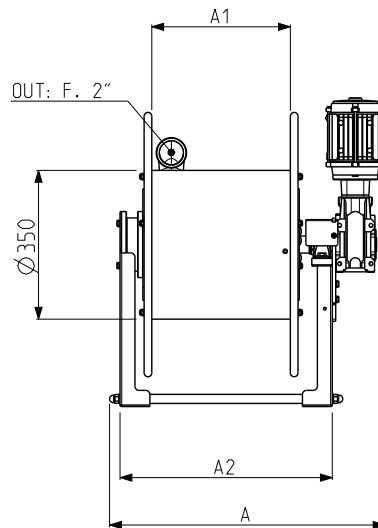
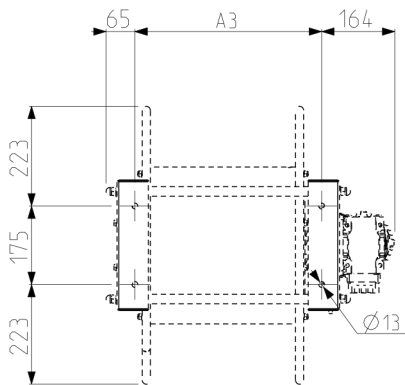

Item-No.	A	A1	A2	A3	kg
2.780.160	830	425	600	520	53
2.780.170	730	325	500	420	51
2.780.195	835	425	600	518	51

